

# **Installation Note**

---

**HP 83620A/B, 22A/B, 23A/B/L, 24A/B, 30A/B/L  
Synthesized Sweepers  
Option 004 Front to Rear Panel Output  
Retrofit Kit 08360-60236**



**HP Part Number 83630-90004 Supersedes: December 1997 printdate  
Printed in USA October 1999**

**Notice.**

The information contained in this document is subject to change without notice.

Hewlett-Packard makes no warranty of any kind with regard to this material, including but not limited to, the implied warranties of merchantability and fitness for a particular purpose. Hewlett-Packard shall not be liable for errors contained herein or for incidental or consequential damages in connection with the furnishing, performance, or use of this material.

© Copyright Hewlett-Packard Company 1997, 1999

All Rights Reserved. Reproduction, adaptation, or translation without prior written permission is prohibited, except as allowed under the copyright laws.

1400 Fountaingrove Parkway, Santa Rosa, CA 95403-1799, USA

# HP 83620A/B, 22A/B, 23A/B/L, 24A/B, 30A/B/L Synthesized Sweepers Option 004 Front to Rear Panel Output Retrofit Kit 08360-60236

---

Product Affected: . . . . .	HP 83620A/B, 22A/B, 23A/B/L, 24A/B, 30A/B/L
Serial Numbers: . . . . .	HP 83620A, 22A, 23A, 24A: 3145A and above . . . . .HP83620B, 22B, 23B/L, 24B, 30A/B/L: all prefixes
To Be Performed By: . . . . .	Customer or HP-qualified personnel

---

## Introduction

This installation note contains the information required to retrofit a standard HP 83620A/B, 22A/B, 23A/B/L, 24A/B, or 30A/B/L synthesizer to an Option 004 (with rear panel output). Having other options on your instrument will not affect this retrofit.

---

## Installation Kit Parts List

**Table 1. Parts Kit 08360-60236 Contents**

Item	Qty	Description	Part Number
1	4	Hole Plug .625 BNC	6960-0135
2	1	Hole Plug .750 RF Out	6960-0137
3	1	RF cable, aux output (W48)	08360-20236
4	1	RF cable, attenuator/rear panel (W43)	08360-20073
5	1	RF cable, AT3/FL2/LPF (W51)	08360-20172
6	1	Rear panel connector plate	08360-00004
7	1	Connector nut	2190-0016
8	1	Connector washer	2950-0001
9	1	Floating BNC cables & PC board (FM, AM, ext ALC Option 004)	08360-60061
10	5	Screws for mounting PC board	0515-0372
11	1	Pulse cable (Option 004 only)	08360-60094
12	1	Pulse cable (Option 002 with Option 004)	08360-60175
13	1	Nut for pulse cable	0590-1251

**Table 1. Parts Kit 08360-60236 Contents (continued)**

<b>Item</b>	<b>Qty</b>	<b>Description</b>	<b>Part Number</b>
14	4	Lock washers for pulse cable and Options 002 and 004 PC board 08360-60186	2190-0102
15	6	Tie wraps	1400-0249
16	1	RF connector (J1)	08673-60040
17	1	Installation Note	83630-90004
18	3	Hex nuts for Options 002 and 004 PC board 08360-60186	2195-0035
19	1	Rear Panel Floating BNC Assembly (FM, AM, ext ALC Options 002 and 004)	08360-60186

---

## **Tools Required**

- #1 x 3-1/8 in. pozidrive screwdriver
- #2 x 4 in. pozidrive screwdriver
- T-10 TORX screwdriver
- T-15 TORX screwdriver
- Small flat bladed screwdriver
- 5/16-in. (6-mm) open-end wrench
- 5-mm ball and socket driver

---

**WARNING** Before you disassemble the instrument, turn the power switch OFF and unplug the instrument. Failure to unplug the instrument can result in personal injury.

---

---

**CAUTION** Electrostatic discharge (ESD) can damage or destroy electronic components. All work on electronic assemblies should be performed at a static-safe workstation. Refer to the documentation that pertains to your instrument for information about static-safe workstations and ordering static-safe accessories.

---

## **Procedure**

1. Disconnect the AC power line cord.
2. Remove the screw from each of the top two feet on the rear panel.
3. Remove the top two feet.
4. Remove the instrument top cover.

---

**NOTE** An RF braid is in each of the side channels on the top of the instrument. When reassembling the instrument, be sure the braid remains in the channels.

---

## Removing the Front Panel

5. Remove the vinyl trim strip from the top front edge of the instrument. (Place a flat screwdriver in either slot in the trim strip and lift to remove; see Figure 1).

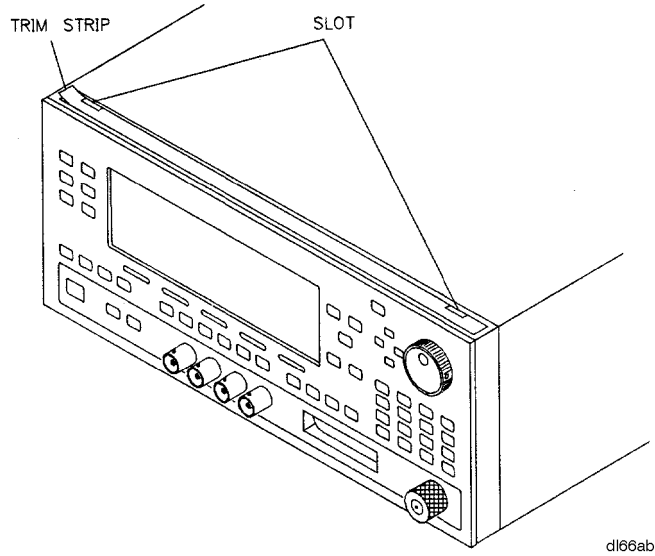

**Figure 1. Front Panel Trim Strip**

6. Refer to Figure 2. Remove *three* of the four screws under the trim strip.
7. Remove *two* of the five screws on the lower front frame edge.

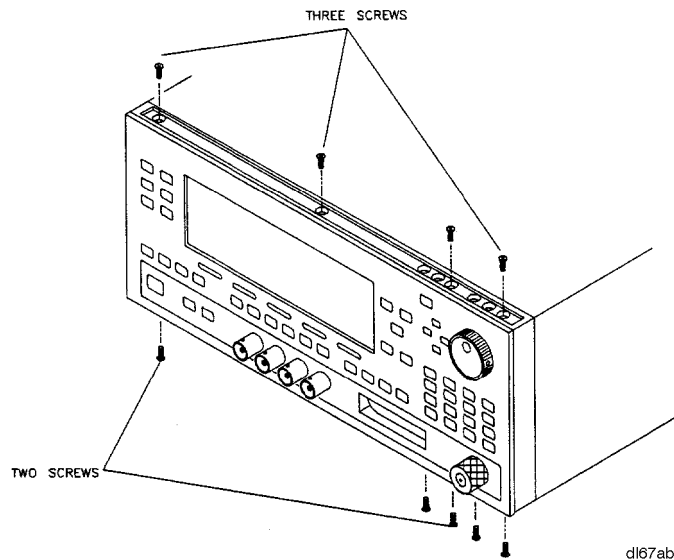

**Figure 2. Front Panel Screw Locations**

8. Gently pry the front panel and display from the frame.
9. Cut the tie wraps holding the cables.

10. Refer to Figure 3. From the A9, A10, and A11 assemblies, disconnect the four coaxial cables attached to the BNC connectors, and the source module interface cable (W10).
11. Disconnect the ribbon cables W2 and W3 from the motherboard.

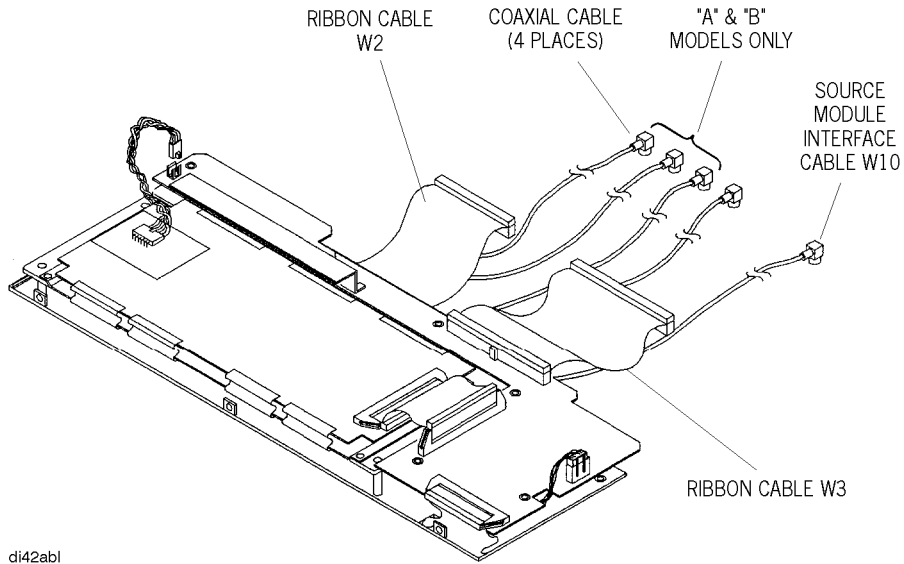

**Figure 3. Front Panel BNC and Ribbon Cable Locations**

### Removing the Front Panel BNC and RF Outputs

12. Refer to Figure 4. Disconnect ribbon cables W4 and W5, the rotary pulse generator (RPG) cable, and the six-wire display cable W1 from the A3 front panel processor.
13. Remove the eight screws from the A3 assembly.
14. Lift off the front panel processor.

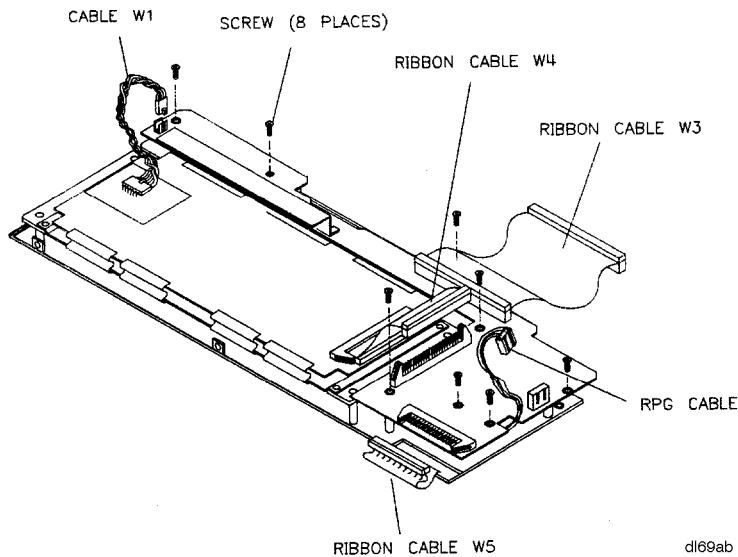

**Figure 4. Front Panel Processor Cables**

15. Refer to Figure 5. Remove the four screws from the source module interface assembly.
16. Lift off the source module interface assembly.

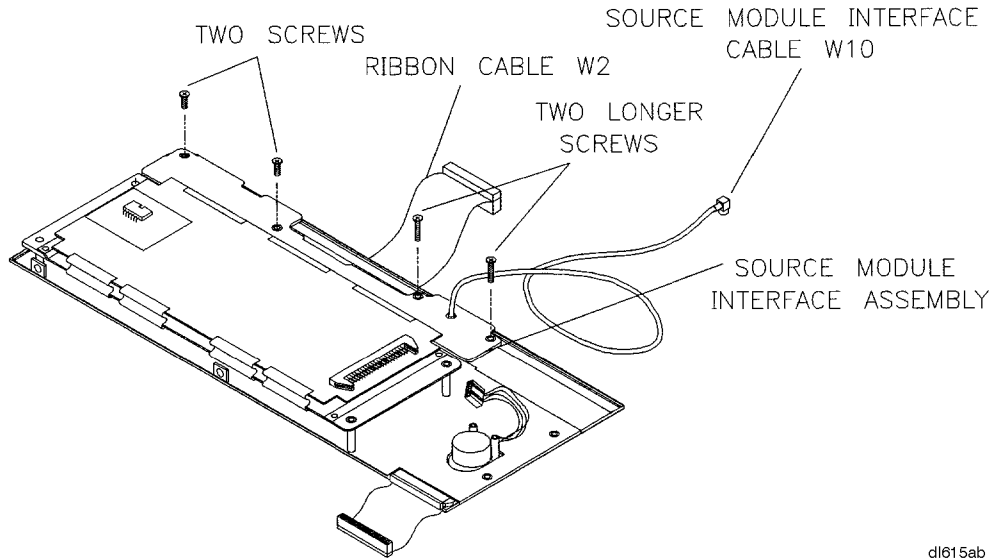

dl615ab

**Figure 5. Source Module Interface**

17. Refer to Figure 6. Remove the two screws on each BNC printed circuit assembly attached to the back of the front panel.
18. Slide out the connectors.

---

**NOTE** If the washer on the front of the connector is not centered properly, loosen the nut to slide the connector out.

---

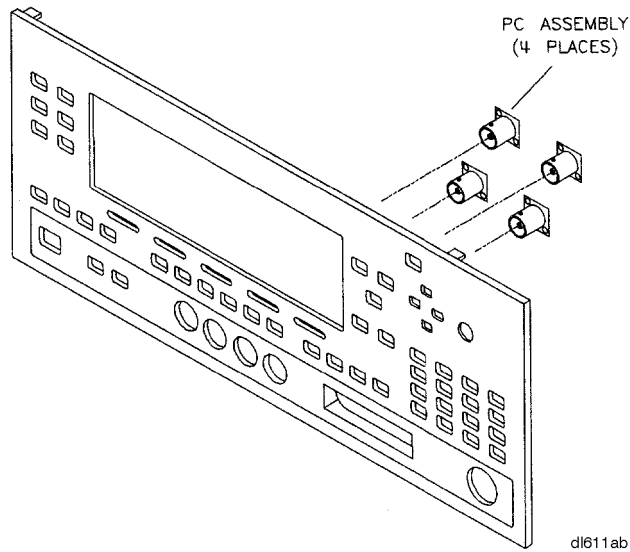

dl611ab

**Figure 6. Front Panel BNC Locations**

19. Place one of the small hole plugs provided in each of the front panel BNC holes.
20. Refer to Figure 7. On the lower front frame edge, remove the two screws that hold the RF output assembly.

---

**CAUTION** To avoid damaging the connector, do not disassemble the RF output connector assembly. Only unscrew the connector on the end of the semi-rigid cable.

---

21. Remove the semi-rigid cable W43 and the RF connector.

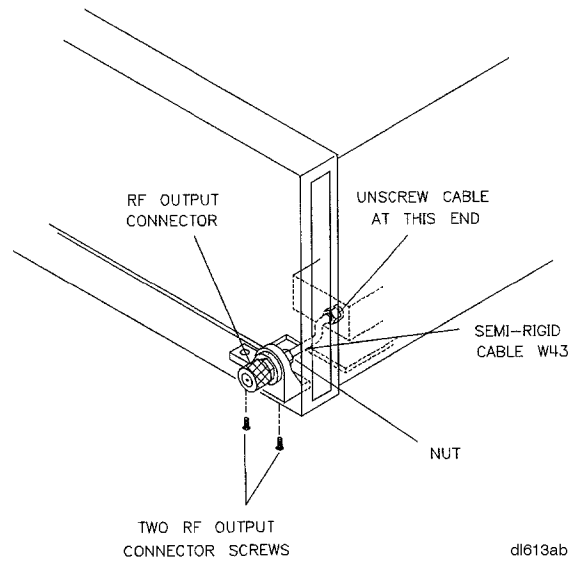
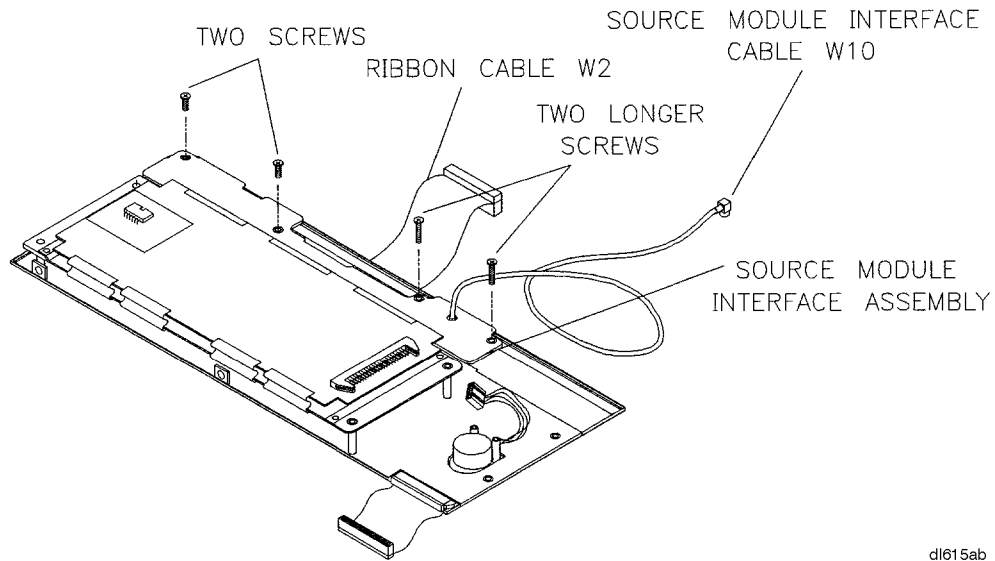

**Figure 7. Removing the RF Output Connector (Front Panel)**



## Replacing the Front Panel

22. Refer to Figure 8. Replace the source module interface assembly and attach it with the four screws removed in step 15.



dl615ab

**Figure 8. Source Module Interface**

23. Refer to Figure 9. Replace the front panel processor and attach it with the eight screws removed in step 13.
24. Connect ribbon cables W4 and W5, the rotary pulse generator (RPG) cable, and the six-wire display cable W1 to the A3 front panel processor.
25. Attach ribbon cables W2 and W3 to the motherboard.

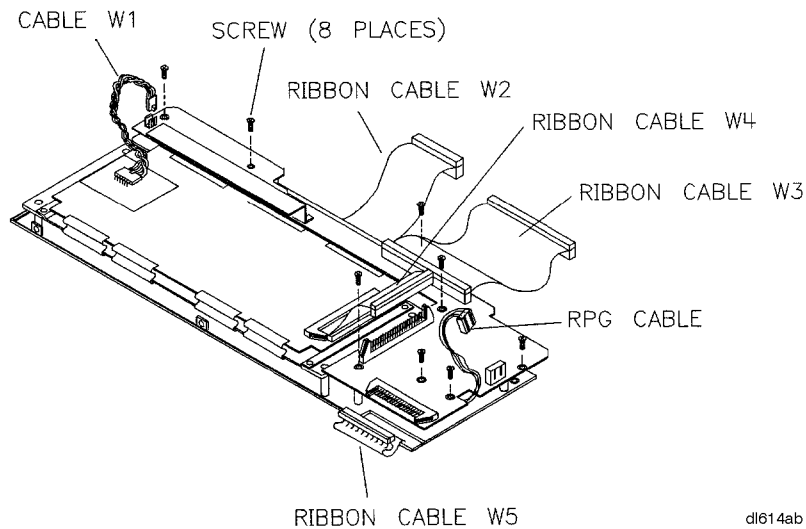

dl614ab

**Figure 9. Front Panel Processor**

26. Replace the front panel in the frame.

27. Replace the two screws on the lower front frame edge.
28. Replace the three screws on the top front frame edge.

### Installing the Rear Panel Outputs

29. If the instrument has a rear panel Aux Output SMA connector, disconnect semi-rigid cable W48 from the rear panel SMA connector.
30. Remove the four bottom feet.
31. Remove the two back feet on the lower edge.
32. Remove the bottom cover, side straps and side panels.
33. Refer to Figure 10. Remove the four screws on the top back edge and the four screws on the bottom back edge.
34. Slide the rear panel out of the casting.

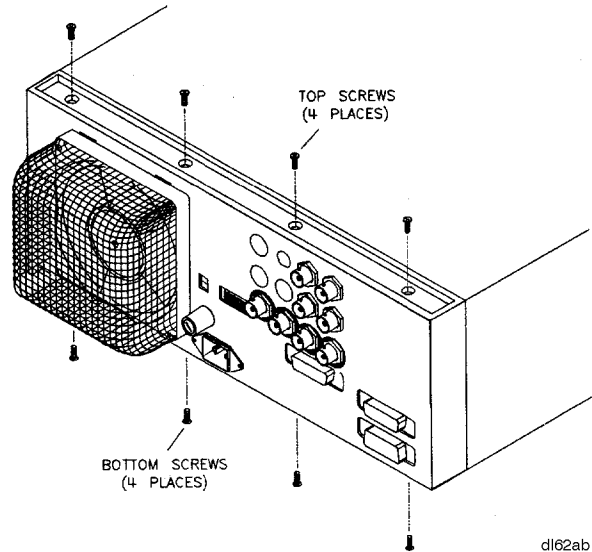

**Figure 10. Rear Panel Removal**

35. Refer to Figure 11. Remove the four hole plugs from the rear panel.
36. Attach the BNC and printed circuit assembly to the rear panel with the five screws provided. (Use 08360-60061 for Option 004 and 08360-60186 for Options 002./004 combination.)
37. Slide the pulse input BNC connector into the rear panel.
38. Place the washer over the BNC connector and attach with the BNC nut.

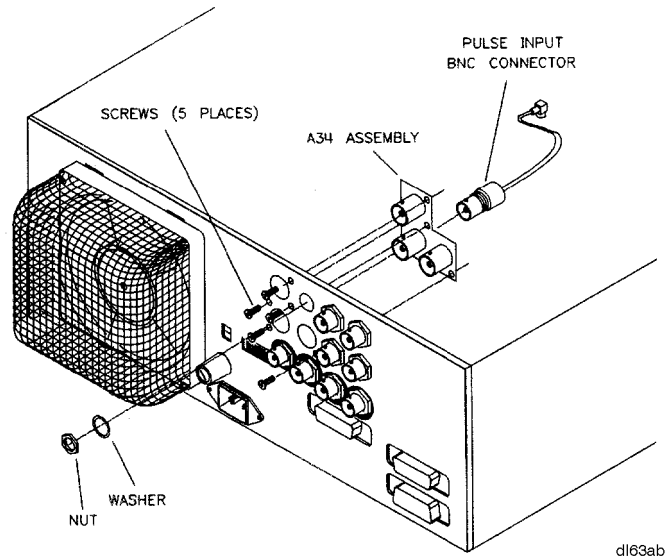

**Figure 11. Option 004 BNC Connector Removal**

39. Slide the rear panel back into the casting.
40. Replace the four screws on the bottom back edge and the four screws on the top back edge.
41. Disconnect W51 from the low pass filter FL2 and attenuator AT3 on the RF deck (Figure 12).

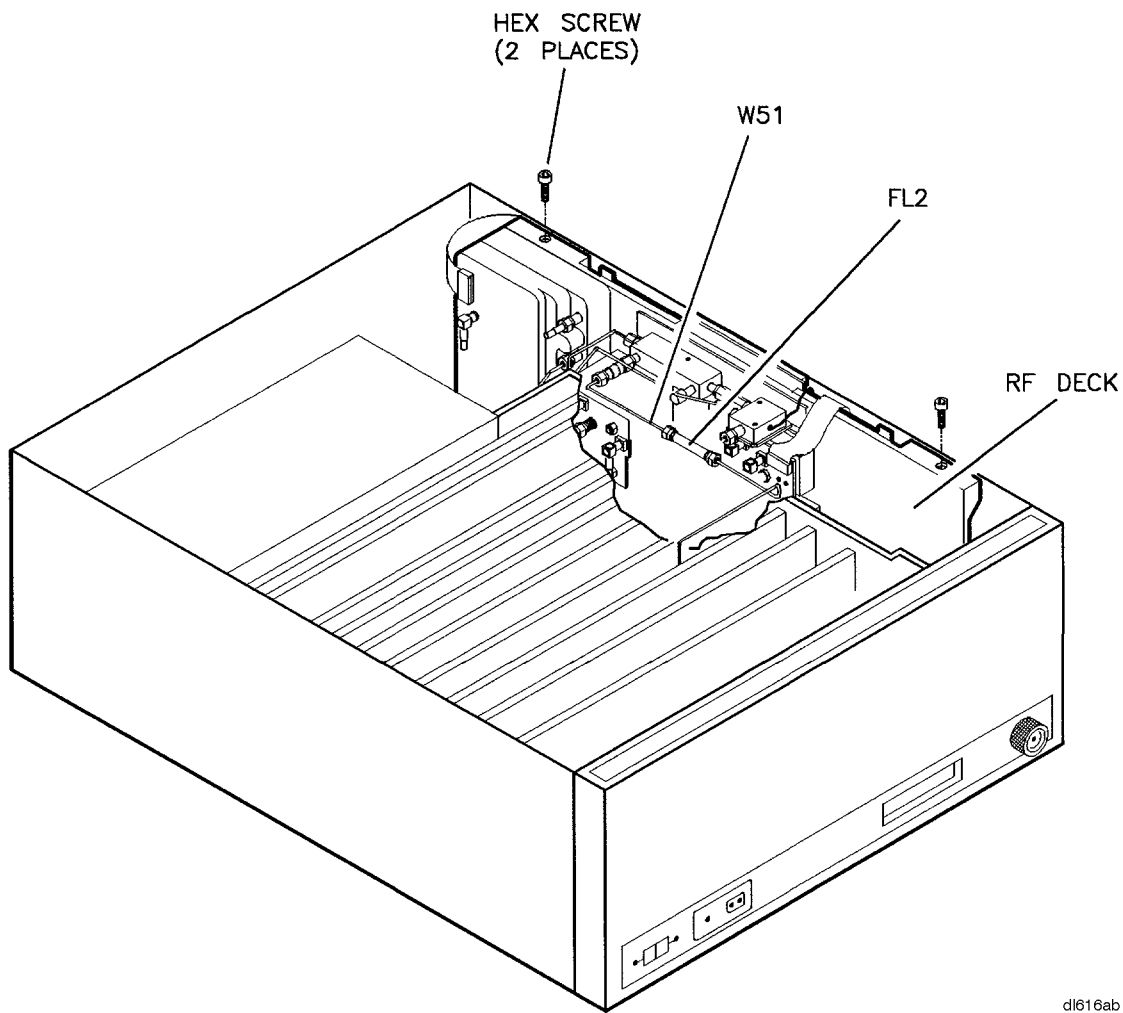

**Figure 12. W51 RF Cable Location**

42. Remove the two hex screws from the RF deck.
43. Carefully pull the RF deck out of the instrument.
44. If the instrument has a rear panel Aux Output, disconnect W48 from the A28 amp/multiplier.
45. Rotate the RF deck 180 degrees (RF Output toward the rear) assuring that all cables remain attached. Refer to Figure 13 to secure the RF deck in the service position.

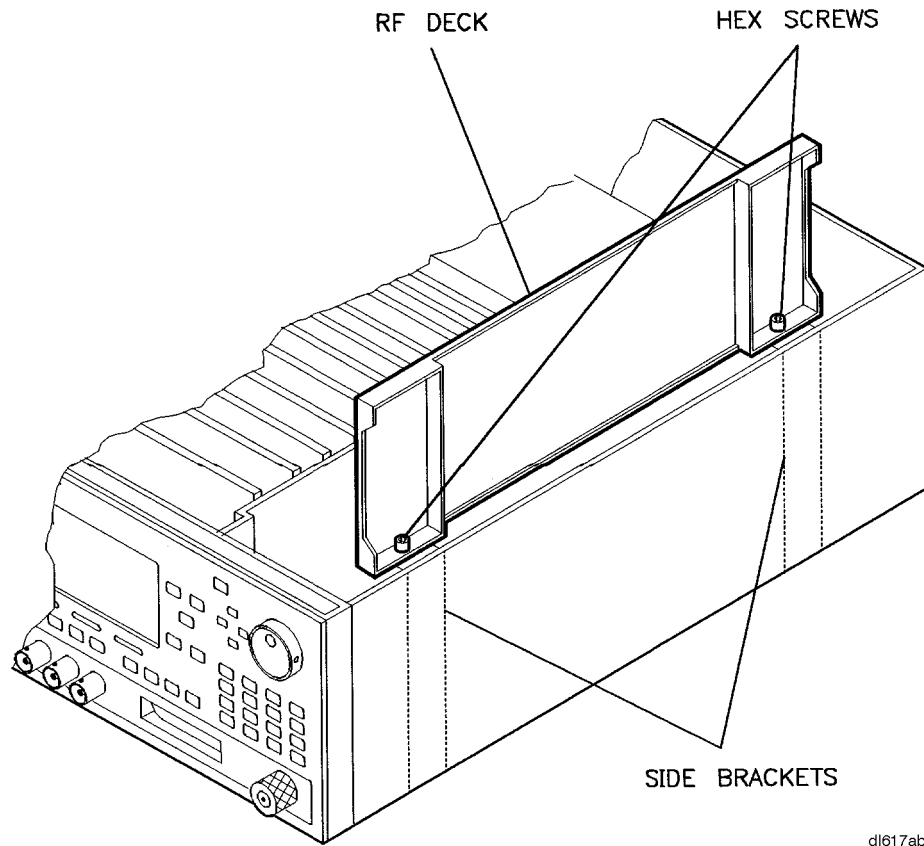

dl617ab

**Figure 13. RF Deck in the Service Position**

46. Connect the new cable W51 to the AT3 attenuator on the RF deck. Position the cable so when the RF deck is installed it will connect to FL2 without any stress on the cable. Make sure the connection to AT3 is tight before installing the RF deck.
47. Replace the deck in the synthesizer. Connect W51 to FL2. Be careful that the cable connection to AT3 remains tight and the cable is not stressed or bent to make the connection. If necessary, remove the RF deck, loosen the W51 connection to AT3 and reposition the cable as required.

---

**NOTE** If the RF deck does not fit easily back into the casting, loosen the RF deck bracket screws on the side of the synthesizer, slide the RF deck into place, and tighten the screws again. See Figure 14.

---

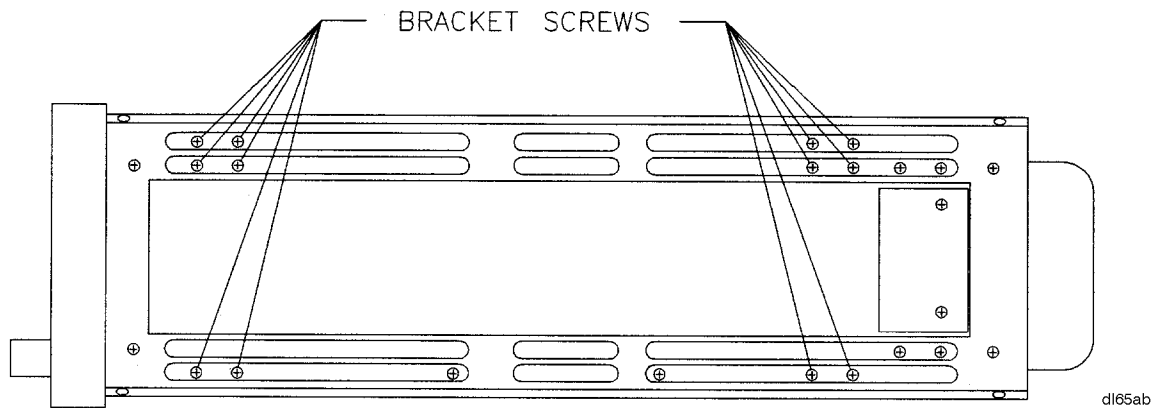
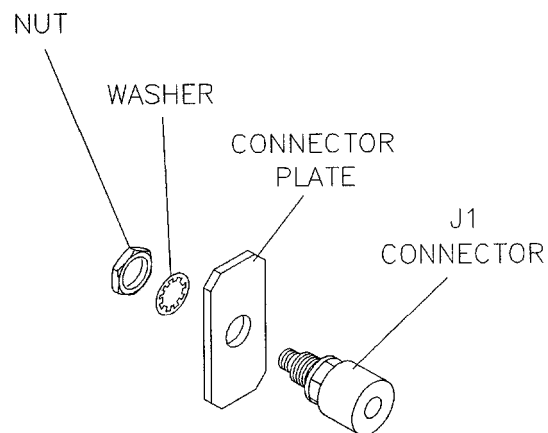

**Figure 14. RF Deck Bracket Screws**

48. Connect the new cable W48 between the A28 amp/multiplier and the rear panel Aux Output SMA connector.

### **Assembling the Rear Panel RF Output Connector**

49. Place the new connector through the new connector plate and attach with the nut and washer supplied in this kit. Refer to Figure 15.



**Figure 15. RF Connector Bracket Assembly for the Rear Panel**

50. Loosely attach W43 to the RF connector.
51. Slide the cable through the rear panel and loosely attach cable W43 to the attenuator or directional coupler (whichever is applicable).
52. Attach the RF plate with the two screws to the rear panel.
53. Tighten the nuts to 10 in-lbs.

## Reassembly

54. Replace the front panel in the frame.
55. Replace the two screws on the lower front frame edge.
56. Replace the three screws on the top front frame edge.
57. Replace the instrument side covers and top and bottom covers. (Be sure to replace the RF braid in the side channels).
58. Replace the four back feet and four bottom feet.
59. Replace the vinyl trim strip on the front edge.

## Hardware Configuration Number

60. The calibration constant for the hardware configuration must be updated to reflect the new configuration. Change the calibration constant and store the constants in memory. If you are unfamiliar with storing calibration constants, instructions are provided in the “Calibration Constants” chapter of the *Service Guide*.
  - Cal Constants: #463
  - Value: +4096 (adding option 004)

## Operation Verification

61. Perform the following adjustments and performance tests.

Adjustments	Performance Tests
None	Full Self-Test
	Power Flatness

---

**NOTE** If any failures occur, perform the Step Attenuator Flatness adjustment (auto) and the Step Attenuator Flatness Test (auto).

---

This completes the installation.